

**SAVE THESE INSTRUCTIONS**

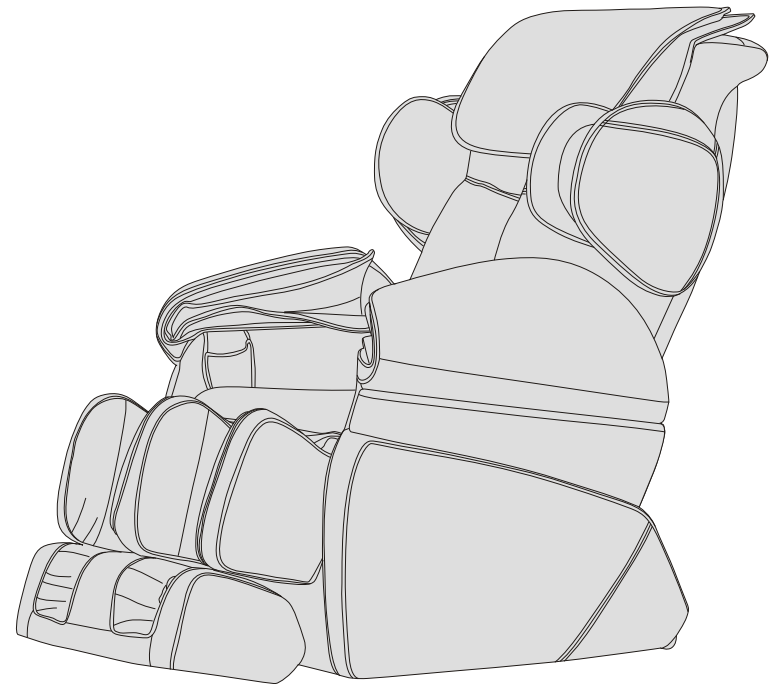

Thanks for purchasing this product. Please read this manual instruction carefully in order to know how to use this product correctly before operation. Please pay more attention to some important safety warning and keep this manual book properly for future use.

Note: Our Company reserves the right to revise the design and description of this product without any further notice. Please refer to the actual color of this product.

## CONTENTS

---

|                                 |    |
|---------------------------------|----|
| Safety and maintenance          | 02 |
| Name and function of components | 04 |
| Function                        | 05 |
| Method of usage                 | 06 |
| Product specification           | 13 |

## Safety And Maintenance

---

### 1. IMPORTANT SAFETY WARNING.

- Don't allow children to touch moveable part of this product.
- Please use well-grounding power supply suited to this product.
- Please pull out the plug after use or before cleaning to avoid injury or Damage to the product.
- Please operate this product according to this manual instruction.
- Don't use accessories which are not recommended.
- Don't use this product outdoors.
- Please read this manual instruction carefully before operation.
- Any other usage that is not listed in this manual instruction is forbidden.
- 15 minutes of usage each time is recommended.
- Please don't use it if the leather is broken or damaged.
- Please don't use it if the cover or leather is damaged.
- Please don't use it if the radiator hole is covered or blocked.
- Please don't drop anything into this product.
- Please don't fall asleep while using this product.
- Please don't use it if drunk or feel unwell.
- Please don't use it within one hour after having meal.
- Please don't make the massage function too strong for avoiding Injury.

#### 2. Environment for usage.

- Please don't use it under high temperature and moist environment such as bathroom.
- Please don't use it immediately while the environmental temperature changes sharply.
- Please don't use it under heavy-dusty or caustic environment.
- Please don't use it where there is not enough space or not good ventilation.

#### 3. People who are not suitable to use this product.

- People who are suffering from osteoporosis are not suitable to use this product.
- People who are suffering from heart disease or carrying electronic medical equipment such as heart pacemaker are not suitable to use this product.
- People who are suffering from fever are not suitable to use this product.
- Pregnant women or women that are in menses period are not suitable to use this product.
- People who got injured or skin disease are not suitable to use this product.
- Children under 14-year old or people mentally unbalanced without being Supervised are not allowed to use this machine.
- People who are told by doctor to have rest or people who feel unwell are not suitable to use this product.
- People whose bodies are wet are forbidden to use this product.

#### 4. Safety.

- Check the voltage if it is suitable to the specification of this product.
- Don't use wet hand to pull the plug.

## Safety And Maintenance

---

- Don't make water go inside this product to avoid electric shock or cause damage to this product.
- Don't damage the wires or change the circuit of this product.
- Don't use wet cloth to clean the electric parts such as switch and plug.
- Be away from this product under power cut state to avoid injury if the power comeback suddenly.
- Stop using this product while it works abnormal, and please consult local agent immediately.
- Stop using this product if you feel unwell, and please consult health care doctor.
- This appliance is not intended for use by persons (including children) with reduced physical, sensory or mental capabilities, or lack of experience and knowledge, unless they have been given supervision or instruction concerning use of the appliance by a person responsible for their safety.
- Children should be supervised to ensure that they do not play with the appliance.
- If the supply cord is damaged, it must be replaced by the manufacturer, its Service agent or similarly qualified persons in order to avoid a hazard.

#### 5. Maintenance.

- This product should be maintained by certain appointed agents, users are prohibited to disassemble or maintain by themselves.
- Please don't forget to cut the power after usage.
- Don't use this product if the socket looses.
- If this product will be left unused for long, please curl up the wires and reserve this product in dry and dustless environment.
- Don't reserve this product under high temperature or near fire and avoid longtime direct sunshine.
- If the detachable cord / supply cord is damaged, it must be replaced by the manufacturer, its service agent or similarly qualified persons in order to avoid a Hazard.
- Please clean this product by dry cloth. Don't use thinner, benzene or alcohol.
- The mechanical components of this product are specially designed and made, it is not necessary to be specially maintained.
- Don't use edged res to thrust this product.
- Don't roll or pull this product above uneven ground, it should be lifted before moving.
- Please use it intermittently; don't make this product work continuously for long.

#### 6. Solution of ordinary malfunctions.

- It is nature movement voice if the motor sounds while in usage.
- If the controller can't work normally, please check the plug and socket if they are connected strongly and make sure the switch is turned on.
- If the rated working time is over, the product will automatically activate the power-off button; If this product works continuously for long, the temperature protector will make the product automatically power-off, it should be used again after half an hour's rest.

## Name And Function Of Components

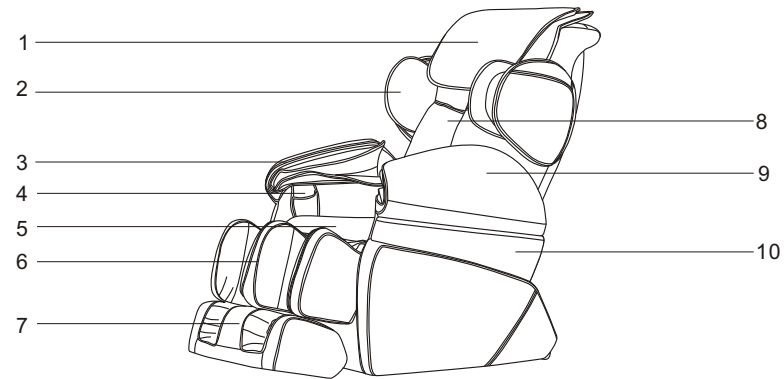

1. Head Cushion
2. Upper arm air bags assembly
3. Arm Airbags
4. Hand Controller Bags
5. seat Cushion
6. Legs Frame
7. Foot Frame
8. Back Cushion
9. Armrest

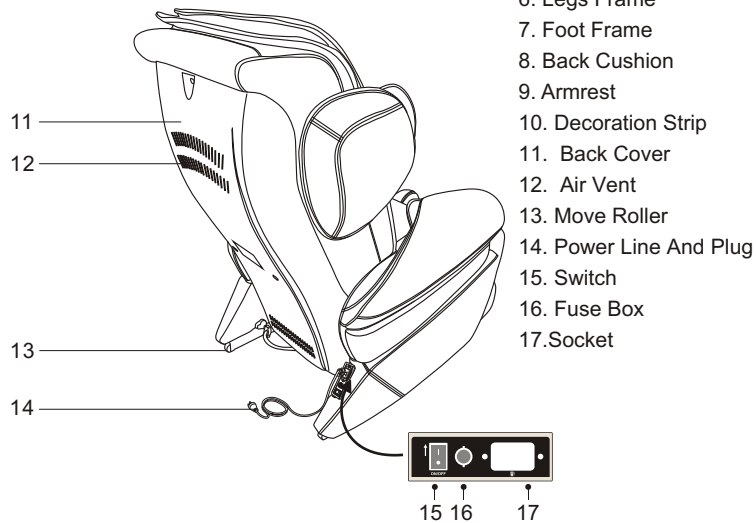

10. Decoration Strip
11. Back Cover
12. Air Vent
13. Move Roller
14. Power Line And Plug
15. Switch
16. Fuse Box
17. Socket

## Function

### Function

- Designed with a set of four wheel driven massage mechanical hands which can move up and down in the back rest
- It can detect massage point on upper body, shoulder position automatically and adjust it.
- Programmed with five human simulating massage mode: shiatsu, kneading, flapping, knocking and synchronism with kneading flapping.
- Programmed with five auto massage modes: auto (overall, neck and shoulder, back and waist), ease, stretch
- Programmed with two memory functions: it can reserve the mode and the angle currently as you like, you can call out next time when you turn on the machine.
- Manual selection of position and mode of massage for upper body: the following three positions of massage may be selected: fixed point, partial, and whole range, there are five speeds for each massage mode. Under the massage of flapping, shiatsu and knocking, the width between the two massage hands can be adjusted in three levels of wide, medium and narrow. On partial and fixed point, the massage hands can move up and down to adjust the massage point accurately.
- Air pressure massage function with three modes: full body air pressure, lower body, arms, set with 41 airbags, three intensity optional.
- With buttocks vibration massage function, and the intensity is adjustable.
- The upper arm is added rotating function to meet different heights people
- Calf rest can extend stepless and turn over freely.
- Calf rest can be lifted separately or together with the backrest, the calf rest can auto segregate when run into barrier.
- Come to sitting up state and mechanical hands reset automatically when power off.
- Setting time 15、 20、 25、 30min, with 4 grade adjustable.

## Method Of Usage

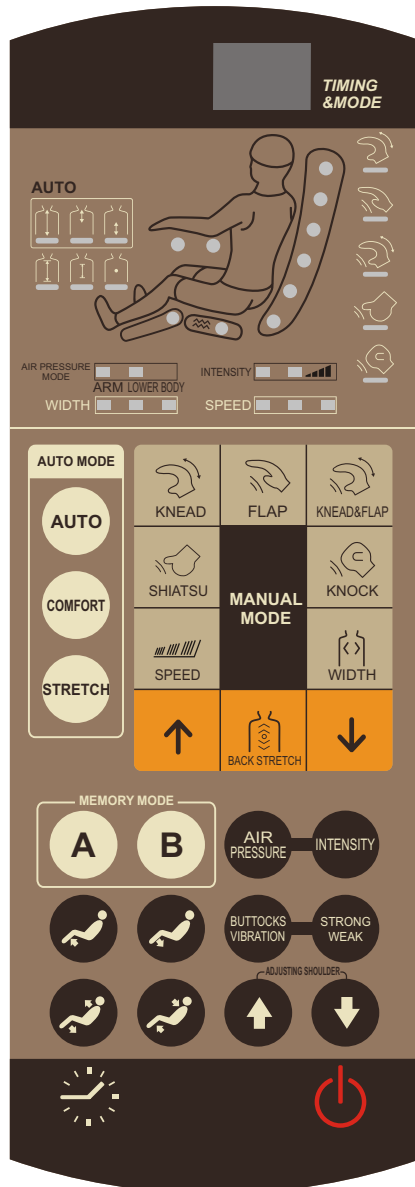

06

## Method Of Usage

### 1. Switch on the power supply of the whole unit

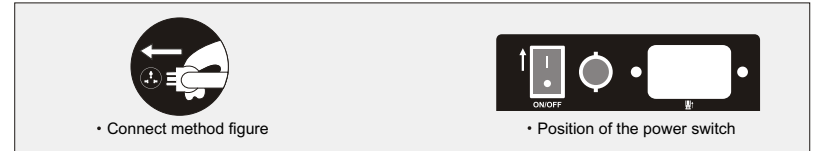

### 2. Adjust the angle of the backrest, footrest, and the retracted position of the foot pad

- Adjust the posture according to your requirement (don't adjust it in massage process)
- Linkage lift adjustment

| Button | Description  |
|--------|--|
|        | Sit up button: press this button, the backrest rise up slowly, calf rest decline slowly, will stop when release the button. If you up to the top, It will stop automatically and with alarm "di-di di....."      |
|        | Lie down button: press this button, the backrest decline slowly, calf rest rise up slowly, will stop when release the button. If you up to the bottom, it will stop automatically and with alarm "di-di di....." |

- Calf rest angle adjust

|  |   |
|--|---|
|  | Calf rest rise button: press this button, the calf rest rise up slowly, stop when release it. If it ups to the top, it will stop automatically and with alarm "di-di di....."       |
|  | Calf rest decline button: press this button, the calf rest decline slowly, stop when release it. If it ups to the bottom, it will stop automatically and with alarm "di-di di....." |

### 3. Start to massage

- 1). Press the red button to start massage.
- 2). First detect shoulder position and massage point, there will be 'Di...Di...' signal after detection. Then the shoulder position can be adjusted and massage chair will automatically adjust to a certain angle. When detecting shoulder position and massage point, you can choose memory mode (memo A and memo B) and automatic mode (auto, comfort and stretch) to enter relative massage mode (jump directly over step 3 and step 4), and the angle automatic adjustment will stop.
- 3). If the roller is not in shoulder position, you can adjust it by pressing up and down button, there are 6 levels.

|  |  |  |
|--|--|--|
| Adjust the position of the massage balls upward to up to a suitable shoulder position.   |  |  |
| Adjust the position of the massage balls downward to up to a suitable shoulder position. |  |  |

07

## Method Of Usage

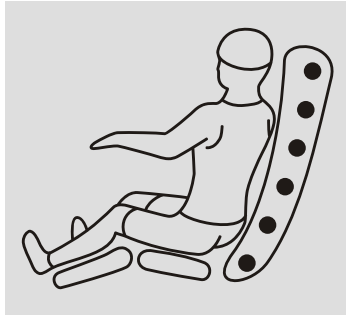

4). Default into ease mode, you can choose other massage modes to massage  
A.Characterized massage, upper body auto massage

| Name                       | Button   | Massage Content           | Massage Feature                                    | Display Status |
|----------------------------|----------|---------------------------|--|----------------|
| Characterized auto massage | MEMORY A | Memory A Massage          | Restore to the stored massage Status a to massage  |                |
|                            | MEMORY B | Memory B Massage          | Restore to the stored massage Status b to massage  |                |
| Auto Massage               | AUTO     | overall massage           | massage on upper body back and forth               | AUTO<br>       |
|                            |          | Neck and shoulder massage | massage focus on neck and shoulders                | AUTO<br>       |
|                            |          | back and waist massage    | massage focus on back and waist                    | AUTO<br>       |
|                            | COMFORT  | Fine massage              | Promote blood circulation, loose bones and muscles | P1             |
|                            | STRETCH  | stretch massage           | Relieve fatigue, refresh yourself.                 | P2             |

B.Upper body manual massage, lower body manual massage  
• Upper body manual massage

| Function     | Button       | Description                                    | Display Status |
|--------------|--------------|--|----------------|
| BACK STRETCH | BACK STRETCH | Upper body( full cover) massage back and forth |                |
|              | BACK STRETCH | Extent (partial) massage back and forth        |                |
|              | BACK STRETCH | Ermanent position (fixed point) massage        |                |

## Method Of Usage

| Function  | Button | Description             | Display Status |
|---|--------|-------------------------|----------------|
| Massage point adjust (in fixed point, partial modes, you can adjust the massage position) |        | Massage hands move up   |                |
|   |        | Massage hands move down |                |

| Function  | button       | description, display status | massage balls adjustment |
|-----------|--------------|-----------------------------|--------------------------|
| Technique | KNEAD        |                             | Speed, intensity         |
|           | FLAP         |                             | speed, width, intensity  |
|           | KNEAD & FLAP |                             | speed, intensity         |
|           | SHIATSU      |                             | speed, width, intensity  |
|           | KNOCK        |                             | speed, width, intensity  |



| Function | Button | Description               | Display Status |
|----------|--------|---------------------------|----------------|
| SPEED    |        | 5 grades speed adjustable | SPEED          |
| WIDTH    |        | 3 grades width adjustable | WIDTH          |

• Lower body air pressure manual massage

| Function     | Button | Description  | Display Status           |
|--------------|--------|--|--------------------------|
| Air pressure |        | Model 1, massage on arms, buttock, foot. 3 grades intensity adjustable                   | AIR PRESSURE MODE<br>    |
|              |        | Model 2, massage on buttock, foot. 3 grades intensity adjustable                         | AIR PRESSURE MODE<br>    |
|              |        | Model 3, massage on arms, 3 grades intensity adjustable                                  | AIR PRESSURE MODE<br>    |
| Intensity    |        | Air-pressure intensity : It has strong, middle, week 3 level of circulatory adjustment . | Strong<br>Middle<br>Week |

## Method Of Usage

### C. Other manual function

| Function           | Button  | Description  | Display Status  |
|--------------------|---|--|---|
| Buttocks vibration |  | buttocks vibration function switch option            |  |
| Strong weak        |  | vibration Strong/ weak 2 options circular adjustment | Strong: LED ON<br>Weak: LED flashing  |

| Function     | Button  | Description   | Display Status |
|--------------|---|---|----------------|
| Time setting |  | With 4 grades massage time adjustable: 15、20、25、30min | 15 MIN         |

### 4. Turn off power, stop massage

- In massage process, press red button, or up to the setting time, all the massage function will stop, the displayer will displayed EE and with glitter, you can press the memory A or B to store the current massage status, in the displayer it will show the corresponding memory status E1 or E2
- Press the red button again, the whole machine will turn off, the massage hands, back rest and calf rest reset; or wait for 10 seconds, turn off automatically, the massage hands, back rest and calf rest reset.

#### NOTES

If the massage time is up, and without memory function, backrest and calf rest cannot restore automatically.

- Cut off the power of the whole machine  
Figure (figure of the power cut off).

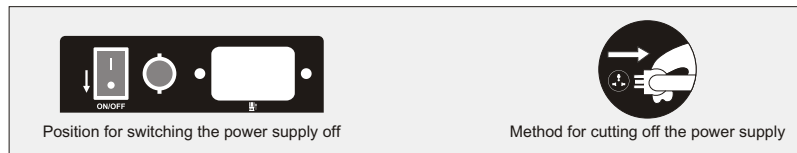

### 5. Calf rest extend infinite or turnover freely

- Calf rest using extend infinite adjust function, fit for different heights using foot support turn over freely, massage on foot at any angle.

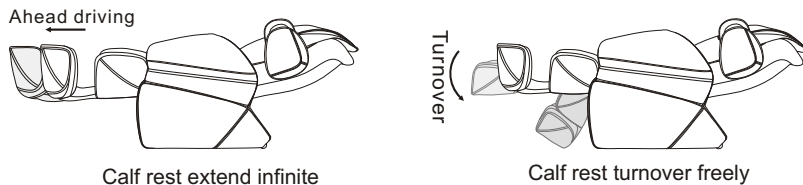

## Method Of Usage

### 6. Upper arms installation

- Zipper the upper arms open which on the rear end, connect the air tubes between backrest frame and upper arms; insert the guide post on the upper arms into corresponding holes on the backrest frames, avoid to bending. (Figure 1)
- Pressing the upper arms and fixing it on the backrest frame with two screws, check the air tube whether it is bending and the zipper is pressing before it is fixed. (Figure 2)
- Pull zipper to the bottom, flapping the surface to make it smoothly. (Figure 3)
- The installation finished. Note: do not yank, press and twist with force when using it. (Figure 4)

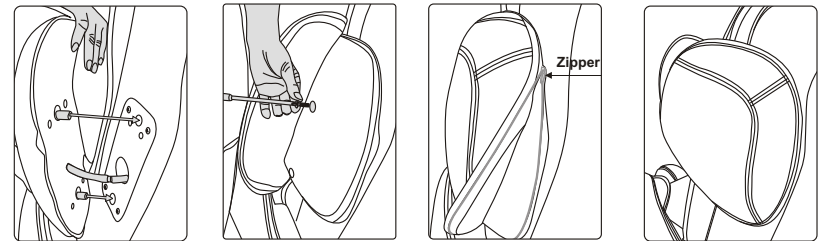

Figure 1

Figure 2

Figure 3

Figure 4

#### NOTES

- When you stand up, cannot with your body press on the two sides top edge of armrest, see figure 1
- Cannot press inward on the top edge of arm rest see figure 2
- Cannot sit on the top edge of armrest see figure 3

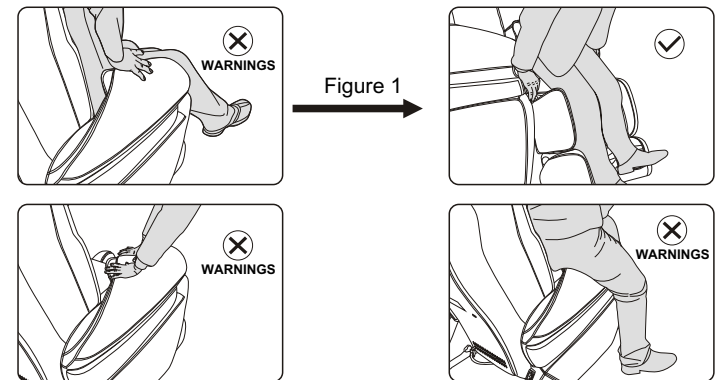

Figure 2

Figure 3

## Method Of Usage

### 7. Pillow and backrest pad's dismounting and use manual.

Using pillows can reduce the kneading massage intensity on shoulder and neck, according to your needs to decide whether the pillow pad is needed (recommend head cushions). Backrest cushion and backrest connected by zipper (1), head cushion and backrest pad connected by thread gluing (2)

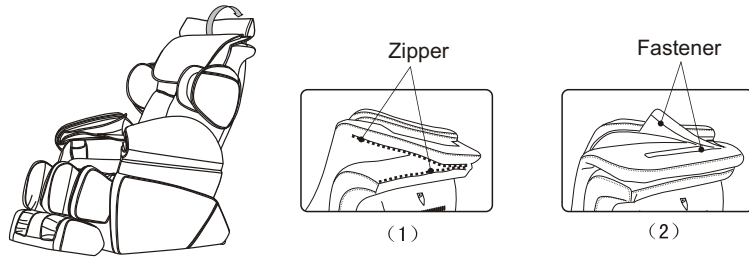

### 8. Floor Protection

Put the heavy massage chairs on the wood floor for a longtime may damage the floor, so please place a carpet or other object to avoid this damage.

Caution: Do not move the chairs with its wheels on wood floor, rough ground or in a narrow space. Two people are required to lift the chair.

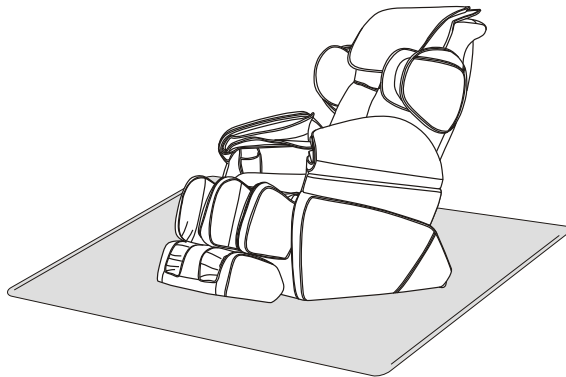

## Method Of Usage

### 9. How to move the chair

Make sure wires are not in your way before you turn the back backward to a proper angle with the gravity center of the chair falls onto the casters. Then pull the chair forward or backward as you wish.

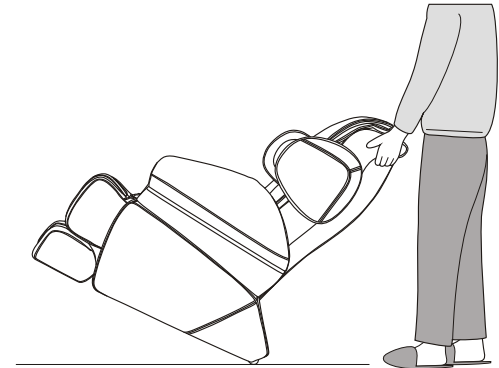

## Product Specification

Model: A52

Name: Massage Chair

Configure: 01

Rated voltage: 110-120V~ 60Hz   
220-240V~ 50Hz/60Hz

Rated power input: 120W

Standby power: around 0.33W

Rated time: 15Min

Safety structure: Class I

Material introduction: PVC, PA, steel parts and electric & ele-ctron parts

| MATERIAL | PU | LEATHER | CLOTH | WOOD |
|----------|----|---------|-------|------|
|          |    |         |       |      |